

## Precision Linear Transducers, Conductive Plastic, up to 1000 mm



### DESIGN SUPPORT TOOLS

[click logo to get started](#)

**3D**  
Models  
Available

The 115 L is a simply mounted, robust, high precision industrial linear motion transducer.

### FEATURES

- Measurement range 25 mm to 1000 mm
- High accuracy  $\pm 1\%$  down to  $\pm 0.025\%$
- Excellent repeatability
- Essentially infinite resolution
- Non sensitive to temperature variations
- Material categorization: for definitions of compliance please see [www.vishay.com/doc?99912](http://www.vishay.com/doc?99912)



**RoHS**  
COMPLIANT

### QUICK REFERENCE DATA

Sensor type	LINEAR, conductive plastic
Output type	Connector
Market appliance	Industrial
Dimensions	L x 31.7 mm x 34.8 mm (with L = TET + 75 mm)

### ELECTRICAL SPECIFICATIONS

Theoretical electrical travel (TET) = E	From 25 mm to 1000 mm in increments of 25 mm
Independent linearity (over TET) on request	$\leq \pm 1\% \leq \pm 0.1\%$ $\leq \pm 0.05\%$ for $E \geq 100$ mm $\leq \pm 0.025\%$ for $E \geq 200$ mm
Actual electrical travel (AET)	AET = TET + 1.5 mm min.
Ohmic values ( $R_T$ )	400 $\Omega$ /cm to 2 k $\Omega$ /cm
Resistance tolerance at 20 °C	$\pm 20\%$
Repeatability	$\leq \pm 0.01\%$
Maximum power rating	0.05 W/cm at 70 °C, 0 W at 125 °C
Wiper current	Recommended: a few $\mu$ A - 1 mA max. (continuous)
Load resistance	minimum $10^3 \times R_T$
Insulation resistance	$\geq 1000$ M $\Omega$ , 500 V <sub>DC</sub>
Dielectric strength	$\geq 1000$ V <sub>RMS</sub> , 50 Hz
Protection resistor	Integrated inside the transducer to protect against errors when setting up (short circuit)

### MECHANICAL SPECIFICATIONS

Mechanical travel	E + 8 $\pm$ 2 mm
Housing	Anodized aluminum
Operating force	7.5 N typical
Shaft (free rotation)	Stainless steel
Termination	Hydraulic type connector DIN 43650
Wiper	Precious metal multifinger
Mounting	Movable brackets

### PERFORMANCE

Operating life	40 million cycles typical / 1 Hz / T° = 20 °C $\pm$ 5 °C / 80 % TET
Temperature range	-55 °C to +125 °C
Sine vibration on 3 axes	1.5 mm peak to peak 0 Hz to 10 Hz 15 g - 10 Hz - 2000 Hz
Mechanical shocks on 3 axes	50 g - 11 ms - half sine
Speed (max.)	8 m/s for f < 2 Hz; 3 m/s for f < 5 Hz

#### Note

- Nothing stated herein shall be construed as a guarantee of quality or durability

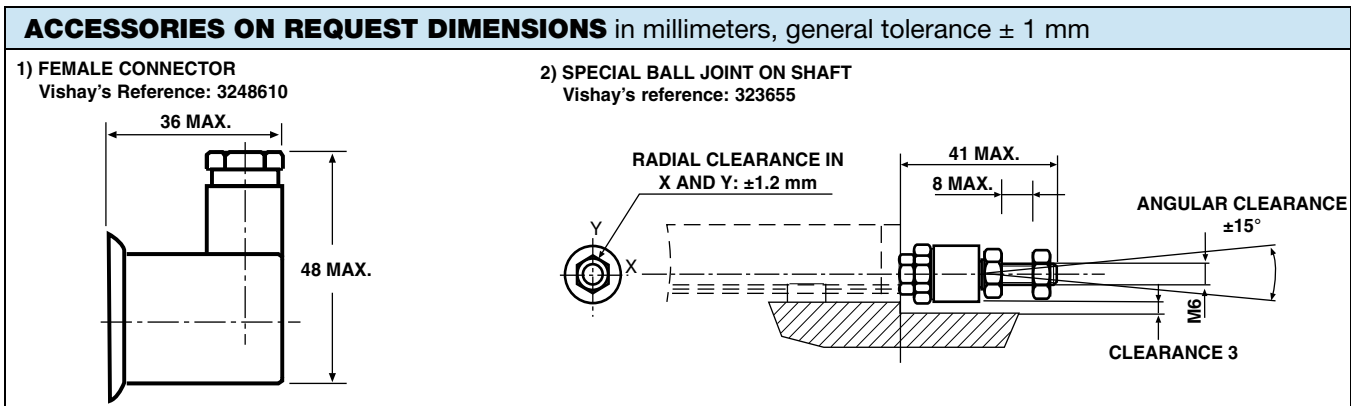
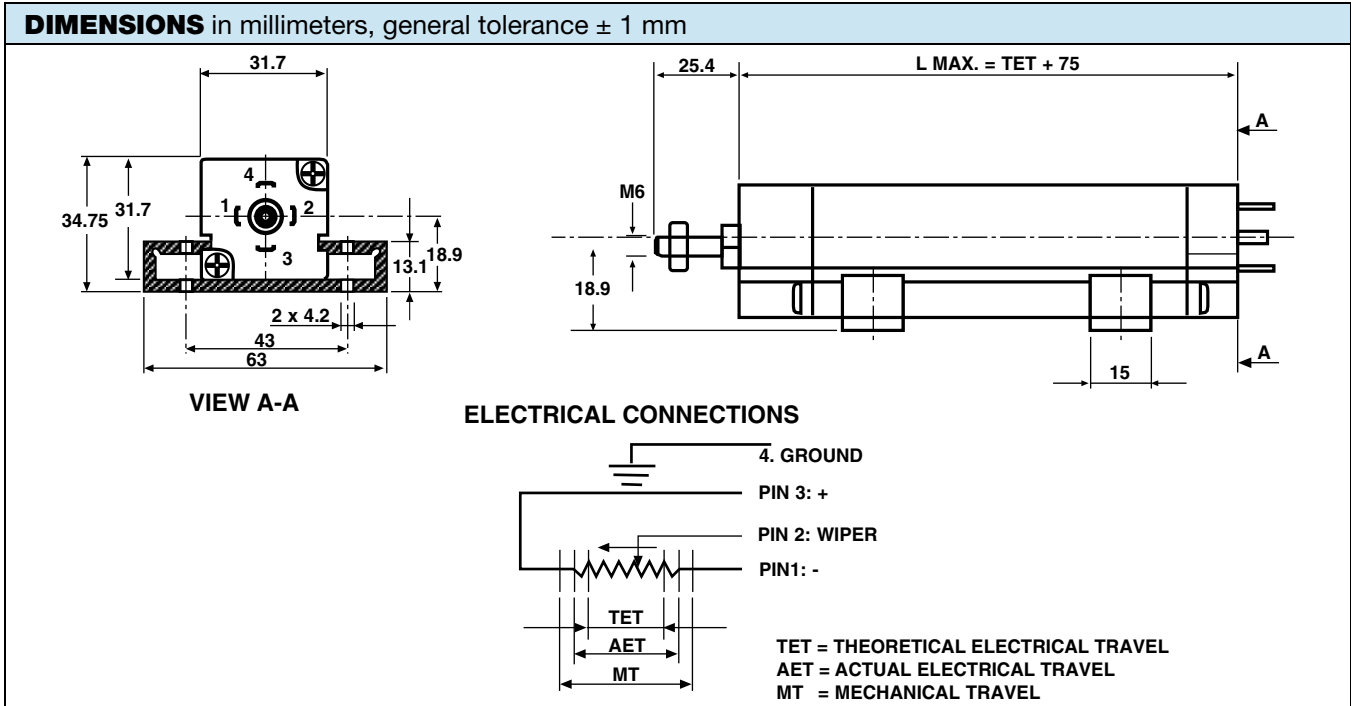

**ORDERING INFORMATION/DESCRIPTION**

REC	115	L	23	D	103	W...	e.
SERIES	MODEL	NUMBER OF TRACKS	THEORETICAL ELECTRICAL TRAVEL	LINEARITY	OHMIC VALUE	MODIFICATIONS	LEAD FINISH
		L = 1	Times 25 mm	A: $\pm 1$ % D: $\pm 0.1$ % E: $\pm 0.05$ % F: $\pm 0.025$ %	First 2 digits are significant numbers 3 <sup>rd</sup> digit indicates number of zeros	Special feature code number	

**SAP PART NUMBERING GUIDELINES**

RE	115 L	23	D	103	W...
SERIES	MODEL	TET	LINEARITY	OHMIC VALUE	SPECIAL FEATURES



## Disclaimer

ALL PRODUCT, PRODUCT SPECIFICATIONS AND DATA ARE SUBJECT TO CHANGE WITHOUT NOTICE TO IMPROVE RELIABILITY, FUNCTION OR DESIGN OR OTHERWISE.

Vishay Intertechnology, Inc., its affiliates, agents, and employees, and all persons acting on its or their behalf (collectively, "Vishay"), disclaim any and all liability for any errors, inaccuracies or incompleteness contained in any datasheet or in any other disclosure relating to any product.

Vishay makes no warranty, representation or guarantee regarding the suitability of the products for any particular purpose or the continuing production of any product. To the maximum extent permitted by applicable law, Vishay disclaims (i) any and all liability arising out of the application or use of any product, (ii) any and all liability, including without limitation special, consequential or incidental damages, and (iii) any and all implied warranties, including warranties of fitness for particular purpose, non-infringement and merchantability.

Statements regarding the suitability of products for certain types of applications are based on Vishay's knowledge of typical requirements that are often placed on Vishay products in generic applications. Such statements are not binding statements about the suitability of products for a particular application. It is the customer's responsibility to validate that a particular product with the properties described in the product specification is suitable for use in a particular application. Parameters provided in datasheets and / or specifications may vary in different applications and performance may vary over time. All operating parameters, including typical parameters, must be validated for each customer application by the customer's technical experts. Product specifications do not expand or otherwise modify Vishay's terms and conditions of purchase, including but not limited to the warranty expressed therein.

Hyperlinks included in this datasheet may direct users to third-party websites. These links are provided as a convenience and for informational purposes only. Inclusion of these hyperlinks does not constitute an endorsement or an approval by Vishay of any of the products, services or opinions of the corporation, organization or individual associated with the third-party website. Vishay disclaims any and all liability and bears no responsibility for the accuracy, legality or content of the third-party website or for that of subsequent links.

Except as expressly indicated in writing, Vishay products are not designed for use in medical, life-saving, or life-sustaining applications or for any other application in which the failure of the Vishay product could result in personal injury or death. Customers using or selling Vishay products not expressly indicated for use in such applications do so at their own risk. Please contact authorized Vishay personnel to obtain written terms and conditions regarding products designed for such applications.

No license, express or implied, by estoppel or otherwise, to any intellectual property rights is granted by this document or by any conduct of Vishay. Product names and markings noted herein may be trademarks of their respective owners.