

Precision Rotative Transducers, Conductive Plastic, Bushing Mounting



A complete range of bushing mounting rotational motion transducers.

QUICK REFERENCE DATA	
Sensor type	ROTATIONAL, conductive plastic
Output type	Output by turrets
Market appliance	Professional
Dimensions	Various sizes

FEATURES

- Size 08 to 30
- Linearity $\pm 1\%$ down to $\pm 0.05\%$
- Good repeatability
- Long life
- Essentially infinite resolution
- Up to 6 electrical functions with the same shaft
- On request custom design to meet your specifications
- Following MIL-R-39023 and NFC 93-255 requirements
- Material categorization: for definitions of compliance please see www.vishay.com/doc?99912



RoHS
COMPLIANT

ELECTRICAL SPECIFICATIONS								
Size	08	09	11	13	15	18	20	30
Model	34 BF	78 BF	116 BF	156 BF	176 BF	134 BF	200 BF	300 BF
Functions	Linear, on request specific law							
Theoretical electrical angle (TEA)	Actual electrical angle (AEA) - 2°							
Independent linearity (over TEA)	A $\leq \pm 1\%$		or B $\leq \pm 0.5\%$		or C $\leq \pm 0.25\%$			
Best linearity available	C $\leq \pm 0.25\%$		Down to D $\leq \pm 0.1\%$			Down to E $\leq \pm 0.05\%$		
Actual electrical angle (AEA)	340° $\pm 3^\circ$		350° $\pm 2^\circ$					
Ohmic values (R _T)	1 k Ω - 2 k Ω - 5 k Ω - 10 k Ω - on request other values							
Ohmic value tolerances at 20 °C	$\pm 10\%$							
Output smoothness	$\leq 0.05\%$					$\leq 0.025\%$		
Maximum power rating at 70 °C	0.25 W	0.3 W	0.4 W	0.5 W	0.75 W	1.0 W	1.2 W	1.5 W
Wiper current	Recommended: a few μA - 1 mA max. (continuous)							
Tap (current or voltage)	U = current		{ Position: $\pm 2^\circ$		/ T = voltage Position: $\pm 2^\circ$			
On request with angular position to be specified			{ Width: $\leq 4^\circ$					
Load resistance on wiper (R _L)	min. 10 ³ x R _T							
Repeatability	$\leq 0.02\%$							
End voltage	$\leq 0.4\%$ for 470 $\Omega \leq R_T \leq 1000 \Omega$ / $\leq 0.2\%$ for 1000 $\Omega < R_T \leq 2200 \Omega$ / $\leq 0.1\%$ for R _T > 2200 Ω							
Insulation resistance	$\geq 1000 \text{ M}\Omega$, 500 V _{DC}							
Dielectric strength	$\geq 750 \text{ V}_{\text{RMS}}$, 50 Hz				$\geq 1000 \text{ V}_{\text{RMS}}$, 50 Hz			

MECHANICAL SPECIFICATIONS								
Mechanical rotation	360° continuous; stops on request							
Mounting type/shaft guiding	Bushings/sleeve bearings; on request ball bearings							
Shaft material/common option	Stainless steel/screw driver slot							
Housing	Plastic molding; on request anodized aluminum							
Termination	Turrets; on request flexible leads, cables...							
Wiper	Precious metal multi-finger contact							
Starting torque (N.cm)	≤ 0.5 1 cup; ≤ 0.3 for each additional cup							
Moment of Inertia (g. cm ²)	0.3	0.4	0.6	0.8	2.2	2.8	3.5	10
Weight (g)	1 cup	11 ± 2	20 ± 2	21 ± 2	30 ± 2	33 ± 2	45 ± 3	120 ± 10
	each additional cup	5 ± 2	6 ± 2	7 ± 2	14 ± 2	16 ± 2	18 ± 3	62 ± 10

PERFORMANCE	
Life (million of cycles)	≥ 20
Temperature range	-55 °C to +125 °C
Climatic category	55/125/04
Rotation speed (RPM)	150

Note

- Nothing stated herein shall be construed as a guarantee of quality or durability

DIMENSIONS in millimeters, general tolerance ± 0.5 mm

Note:
• On Request

DIMENSIONS	DESIGNATION	SIZE	POTENTIOMETER REFERENCE							
			08	09	11	13	15	18	20	30
			MODEL	34 BF	78 BF	116 BF	156 BF	176 BF	134 BF	200 BF
A - 0 - 0.013	Ø shaft		3.175	3.175	3.175	3.175	6.345	6.345	6.345	6.345
C max.	Ø body		19.18	22.3	27.07	33.35	36.6	44.5	50.9	76.4
H min.	Turret location		4.2	4.7	5.35	5.35	8	8	7.45	5.55
I max.	Radius on turrets		14	15.4	17.3	20.8	23.1	26.6	29.7	43.7
J max.	Radius on screw clamp		13.5	15.4	17.3	18.9	23.1	26.5	29.3	42.6
K	Ø on clamp		19.6	23.8	27.7	33.6	37.4	44.5	50.8	77.5
O	Locating pin (on request)		7.2	8	8.8	9	14.4	16.8	13.48	-
P max.	Ø pin (on request)		1.6	1.6	3.25	3.25	3.25	3.25	-	-
L ± 2°	Angle between turrets		30°	30°	25°	20°	20°	25°	15°	15°
M max.	Total angle		100°	100°	100°	100°	80°	80°	80°	80°
N max.	1 cup		14.5	19	19	19	21	21	21	20.5
	2 cups		21.5	25	21.5	24	24.5	24.5	26	23.5
	3 cups		34.5	38	34.5	38	37.5	37.5	38	-
	4 cups		40.5	48	40.5	45.5	48	48	48	-
	5 cups		53	61	53	59	60.5	61	62	-
	6 cups		59	72	59	67	72	72	72	-



ORDERING INFORMATION/DESCRIPTION								
ROT	156	B	F	1	C	T	502	e1
SERIES	SIZE	MOUNTING TYPE	CONDUCTOR	NUMBER OF CUPS	LINEARITY	TAP	OHMIC VALUE	LEAD FINISH
		B: Bushing	F: Plastic film	From 1 up to 6	A: ± 1 % B: ± 0.5 % C: ± 0.25 % D: ± 0.1 % E: ± 0.05 %	On request T: Voltage U: Current position to be specified	First 2 digits are significant numbers 3rd digit indicates number of zeros	

Note

- Special characteristics and designs on request

SAP PART NUMBERING GUIDELINES			
RO 116BF	1	D	103
MODEL	GANG NUMBER	LINEARITY	OHMIC VALUE
	From 1 up to 6		10 kΩ



Disclaimer

ALL PRODUCT, PRODUCT SPECIFICATIONS AND DATA ARE SUBJECT TO CHANGE WITHOUT NOTICE TO IMPROVE RELIABILITY, FUNCTION OR DESIGN OR OTHERWISE.

Vishay Intertechnology, Inc., its affiliates, agents, and employees, and all persons acting on its or their behalf (collectively, "Vishay"), disclaim any and all liability for any errors, inaccuracies or incompleteness contained in any datasheet or in any other disclosure relating to any product.

Vishay makes no warranty, representation or guarantee regarding the suitability of the products for any particular purpose or the continuing production of any product. To the maximum extent permitted by applicable law, Vishay disclaims (i) any and all liability arising out of the application or use of any product, (ii) any and all liability, including without limitation special, consequential or incidental damages, and (iii) any and all implied warranties, including warranties of fitness for particular purpose, non-infringement and merchantability.

Statements regarding the suitability of products for certain types of applications are based on Vishay's knowledge of typical requirements that are often placed on Vishay products in generic applications. Such statements are not binding statements about the suitability of products for a particular application. It is the customer's responsibility to validate that a particular product with the properties described in the product specification is suitable for use in a particular application. Parameters provided in datasheets and / or specifications may vary in different applications and performance may vary over time. All operating parameters, including typical parameters, must be validated for each customer application by the customer's technical experts. Product specifications do not expand or otherwise modify Vishay's terms and conditions of purchase, including but not limited to the warranty expressed therein.

Hyperlinks included in this datasheet may direct users to third-party websites. These links are provided as a convenience and for informational purposes only. Inclusion of these hyperlinks does not constitute an endorsement or an approval by Vishay of any of the products, services or opinions of the corporation, organization or individual associated with the third-party website. Vishay disclaims any and all liability and bears no responsibility for the accuracy, legality or content of the third-party website or for that of subsequent links.

Except as expressly indicated in writing, Vishay products are not designed for use in medical, life-saving, or life-sustaining applications or for any other application in which the failure of the Vishay product could result in personal injury or death. Customers using or selling Vishay products not expressly indicated for use in such applications do so at their own risk. Please contact authorized Vishay personnel to obtain written terms and conditions regarding products designed for such applications.

No license, express or implied, by estoppel or otherwise, to any intellectual property rights is granted by this document or by any conduct of Vishay. Product names and markings noted herein may be trademarks of their respective owners.

Precision Rotative Transducers, Conductive Plastic, Servo Mounting



A complete range of servo mounting rotational transducers for applications requiring long life accuracy and speed.

FEATURES

- Size 08 to 30
- Linearity $\pm 1\%$ down to $\pm 0.015\%$
- Excellent repeatability
- Long life
- Essentially infinite resolution
- Up to 6 electrical functions with the same shaft
- On request custom design to meet your specifications
- Following MIL-R-39023 and NFC 93-255 requirements
- Material categorization: for definitions of compliance please see www.vishay.com/doc?99912



RoHS
COMPLIANT

QUICK REFERENCE DATA

Sensor type	ROTATIONAL, conductive plastic
Output type	Output by turrets
Market appliance	Professional
Dimensions	Various sizes

ELECTRICAL SPECIFICATIONS

Size	08	09	11	13	15	18	20	30
Model	34 SF	78 SF	116 SF	156 SF	176 SF	134 SF	200 SF	300 SF
Functions	Linear, on request specific law							
Theoretical electrical angle (TEA)	TEA = actual electrical angle (AEA) - 2°							
Independent linearity (over TEA)	A $\leq \pm 1\%$ or B $\leq \pm 0.5\%$ or C $\leq \pm 0.25\%$ or D $\leq \pm 0.1\%$							
On request best linearity available	D $\leq \pm 0.1\%$		Down to E $\leq \pm 0.05\%$		Down to F $\leq \pm 0.025\%$		Down to $\leq \pm 0.015\%$	
Actual electrical angle (AEA)	340° $\pm 3^\circ$			350° $\pm 2^\circ$				
Ohmic values (R _T)	1 k Ω - 2 k Ω - 5 k Ω - 10 k Ω - on request other values							
Ohmic value tolerances at 20 °C	$\pm 10\%$; on request $\pm 5\%$							
Output smoothness	$\leq 0.025\%$						On request $\leq 0.01\%$	
Maximum power rating at 70 °C	0.25 W	0.3 W	0.4 W	0.5 W	0.75 W	1.0 W	1.2 W	1.5 W
Wiper current/load resistance	Recommended: a few μA - 1 mA max. continuous/minimum $10^3 \times R_T$							
Tap (current or voltage)	U = Current				{ Position: $\pm 2^\circ$		{ Width: $\leq 4^\circ$ /T = voltage Position: $\pm 2^\circ$	
On request with angular position to be specified								
Repeatability	$\leq 0.01\%$							
End voltage	$\leq 0.4\%$ for 470 Ω v R _T $\leq 1000 \Omega$ / $\leq 0.2\%$ for 1000 $\Omega \leq R_T \leq 2200 \Omega$ / $\leq 0.1\%$ R _T > 2200 Ω							
Insulation resistance	$\geq 1000 \text{ M}\Omega$, 500 V _{DC}							
Dielectric strength	$\leq 750 \text{ V}_{\text{RMS}}$, 50 Hz				$\leq 1000 \text{ V}_{\text{RMS}}$, 50 Hz			

MECHANICAL SPECIFICATIONS

Mechanical rotation	360° continuous; stops on request							
Mounting/shaft guiding	Servo/ball bearings							
Housing	Diallylphthalate; on request anodized aluminum							
Shaft material/common option	Stainless steel/screw driver slot							
Termination	Turrets; on request flexible leads, cables...							
Wiper	Precious metal multi-finger contact							
Starting torque (N.cm)	1 cup		0.2		0.15		0.25	
	each additional cup							
Moment of inertia (g. cm ²)	0.3	0.4	0.6	0.8	2.2	2.8	3.5	10
Weight (g)	1 cup		20 ± 2		49 ± 2		120 ± 10	
	each additional cup		5 ± 2	6 ± 2	7 ± 2	10 ± 2	16 ± 2	18 ± 3

PERFORMANCE

Life (million of cycles)	≥ 50							
Temperature range	-55 °C to +125 °C							
Climatic category	55/125/04							
Maximum rotation speed (RPM)	600							
Sine vibration on 3 axes	1.5 mm or 20 g from 10 Hz to 2000 Hz							
Mechanical shocks on 3 axes	50 g - 11 ms - half sine							

Note

- Nothing stated herein shall be construed as a guarantee of quality or durability.

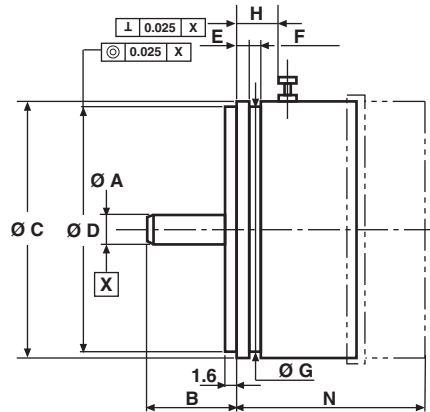
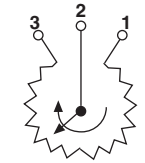
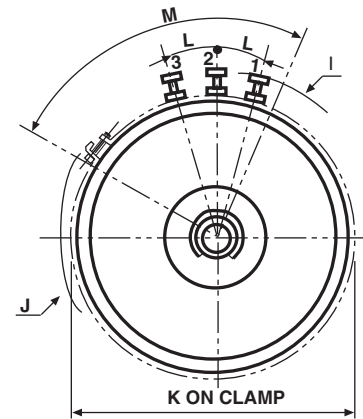
DIMENSIONS in millimeters, general tolerance ± 0.5 mm

ELECTRICAL CONNECTIONS

 CLOCK WISE
VIEWED FROM
SHAFT SIDE

DIMENSIONS	DESIGNATION	SIZE	POTENTIOMETER REFERENCE							
			08	09	11	13	15	18	20	30
			MODEL	34 SF	78 SF	116 SF	156 SF	176 SF	134 SF	200 SF
A - 0 - 0.013	Ø shaft stainless steel		3.175	3.175	3.175	3.175	6.345	6.345	6.345	6.345
B max.	Shaft length		13	16.6	16.6	16.6	16.6	16.6	16.6	16.6
C max.	Ø body plastic molded		19.18	22.3	27.07	33.35	36.6	44.5	50.9	76.3
D	Ø flange		15.875	19.05	24.608	30.16	33.337	39.674	47.625	73.025
	Tolerance on flange		+0 - 13 µm						+0 - 25 µm	
E	Shoulder		1.6	1.6	1.6	1.6	1.6	1.6	2.4	2.4
F min.	Width of groove		1.5	1.5	1.5	1.5	2.2	1.8	2.2	1.75
Ø G max.	Diameter of groove		17.57	19.8	24.8	30.9	33.3	41.4	47.6	73.1
H min.	Turret location		5.8	5.95	6.3	6.3	7	10.15	10.2	10.2
I max.	Radius on turrets		14	15.4	17.3	20.5	23.1	26.5	29.7	43.7
J max.	Radius on screw clamp		13.5	15.4	17.3	18.9	23.1	26.5	29.7	42.6
K max.	Ø on clamp		19.6	23.8	27.7	33.6	37.4	44.5	50.8	77.5
L $\pm 2^\circ$	Angle between turrets		30°	30°	25°	20°	20°	25°	15°	15°
M max.	Total angle		100°	100°	100°	100°	80°	80°	80°	80°
N max.	1 cup		16	20.5	20.5	20.5	23.5	23.5	23.5	23
	2 cups		23	27	23	25.5	26.13	26	28.5	34.5
	3 cups		36	40	36	39.5	39.5	39.5	40.97	-
	4 cups		42	50	42	47	49.5	49.5	50.72	-
	5 cups		54.5	63	54	60.5	62.5	62.5	64.5	-
	6 cups		60.5	74	60.5	68.5	73.5	73.5	74.5	-

ORDERING INFORMATION/DESCRIPTION

ROT	156	S	F	1	C	T	502	e1
SERIES	MODEL	MOUNTING TYPE	CONDUCTOR	NUMBER OF CUPS	LINEARITY	TAP	OHMIC VALUE	LEAD FINISH
		S: Servo	F: Plastic film	From 1 up to 6	A: $\pm 1\%$ B: $\pm 0.5\%$ C: $\pm 0.25\%$ D: $\pm 0.1\%$ E: $\pm 0.05\%$ F: $\pm 0.025\%$	On request T: Voltage U: Current position to be specified	First 2 digits are significant numbers 3 rd digit indicates number of zeros	

Note

- Special characteristics designs on request

SAP PART NUMBERING GUIDELINES

RO 116SF	1	D	502
MODEL	GANG NUMBER	LINEARITY	OHMIC VALUE
	From 1 up to 6		5 kΩ



Disclaimer

ALL PRODUCT, PRODUCT SPECIFICATIONS AND DATA ARE SUBJECT TO CHANGE WITHOUT NOTICE TO IMPROVE RELIABILITY, FUNCTION OR DESIGN OR OTHERWISE.

Vishay Intertechnology, Inc., its affiliates, agents, and employees, and all persons acting on its or their behalf (collectively, "Vishay"), disclaim any and all liability for any errors, inaccuracies or incompleteness contained in any datasheet or in any other disclosure relating to any product.

Vishay makes no warranty, representation or guarantee regarding the suitability of the products for any particular purpose or the continuing production of any product. To the maximum extent permitted by applicable law, Vishay disclaims (i) any and all liability arising out of the application or use of any product, (ii) any and all liability, including without limitation special, consequential or incidental damages, and (iii) any and all implied warranties, including warranties of fitness for particular purpose, non-infringement and merchantability.

Statements regarding the suitability of products for certain types of applications are based on Vishay's knowledge of typical requirements that are often placed on Vishay products in generic applications. Such statements are not binding statements about the suitability of products for a particular application. It is the customer's responsibility to validate that a particular product with the properties described in the product specification is suitable for use in a particular application. Parameters provided in datasheets and / or specifications may vary in different applications and performance may vary over time. All operating parameters, including typical parameters, must be validated for each customer application by the customer's technical experts. Product specifications do not expand or otherwise modify Vishay's terms and conditions of purchase, including but not limited to the warranty expressed therein.

Hyperlinks included in this datasheet may direct users to third-party websites. These links are provided as a convenience and for informational purposes only. Inclusion of these hyperlinks does not constitute an endorsement or an approval by Vishay of any of the products, services or opinions of the corporation, organization or individual associated with the third-party website. Vishay disclaims any and all liability and bears no responsibility for the accuracy, legality or content of the third-party website or for that of subsequent links.

Except as expressly indicated in writing, Vishay products are not designed for use in medical, life-saving, or life-sustaining applications or for any other application in which the failure of the Vishay product could result in personal injury or death. Customers using or selling Vishay products not expressly indicated for use in such applications do so at their own risk. Please contact authorized Vishay personnel to obtain written terms and conditions regarding products designed for such applications.

No license, express or implied, by estoppel or otherwise, to any intellectual property rights is granted by this document or by any conduct of Vishay. Product names and markings noted herein may be trademarks of their respective owners.