

Heatsink Encased Wirewound Power Resistors

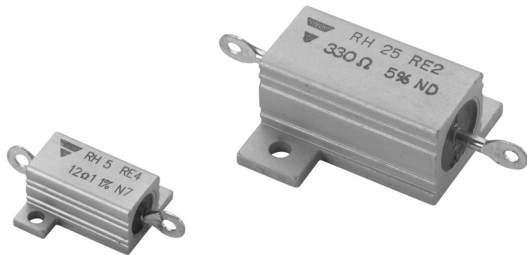

FEATURES

- 5 Watt to 50 Watt at 25°C
- MIL-R 18546 D and 1C
- NF C 83-210
- CECC 40 203
- High stability < 0.05% year
- Electrical insulation
- Low temperature coefficient
- Wide range of values

Encased in a compact and light heatsink offering complete environmental protection, great mechanical strength and easy mounting. Non inductive versions can be supplied under the RHNI designation (please indicate required specifications and frequency range upon ordering).

DIMENSIONS in millimeters

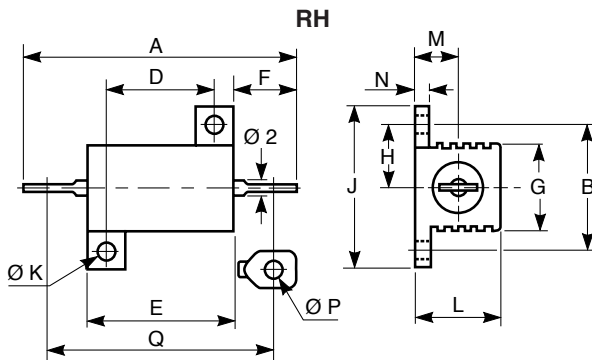

MODEL AND STYLE	RH5	RH10	RH25	RH50
A	28.5 ± 1.5	35 ± 1.5	49 ± 1.3	70.2 ± 1.4
B ± 0.2	12.5	15.9	19.8	21.4
D ± 0.2	11.3	14	18.3	39.7
E ± 0.5	16.3	19	28	50
F	6.8 ± 1.5	7.9 ± 1.5	11.1 ± 1.5	11 ± 1.2
G ± 1	8.5	11	14	15.5
H ± 0.7	6.2	7.9	9.9	10.7
J ± 0.5	16.4	20.6	27.5	29.4
Ø K ± 0.1	2.4	2.4	3.2	3.2
L max.	8.9	11	15	15
M ± 0.5	4.3	5.6	8	8
N ± 0.3	1.6	2	2.4	2.4
Ø P min.	2.1	2.1	2.1	2.1
Q	25.3 ± 1.5	30.6 ± 1.5	44.6 ± 1.3	66.5 ± 1.4
Weight in g	3	8.8	16.5	30.8

ELECTRICAL SPECIFICATIONS							
VISHAY SFERNICE MODEL AND STYLE			RH5 €	RH10 €	RH25 €	RH50 €	
NF C 83-210 (CECC 40 203)			RE4	RE1	RE2	RE3	
MIL-R-18546 D AND 1C			RE60	RE65	RE70	RE75	
Power Rating	Chassis Mounted Resistors	MIL Limits	25°C	5W	10W	20W	30W
			70°C	4W	8W	16W	24W
	413 cm ² for RH5 and RH10 536 cm ² for RH25 and RH50	VISHAY SFERNICE Limits	25°C	10W	12.5W	25W	50W
			70°C	8W	10W	20W	40W
Unmounted Resistors	VISHAY SFERNICE Limits	25°C	4W	6W	9W	12W	
		70°C	3.2W	4.8W	7.2W	9.6W	
Rated Maximum Voltage (VRMS)			160V	250V	550V	1285V	
Dielectric Strength (RMS)			1000V	1500V	2500V	2500V	
Ohmic Range		VISHAY SFERNICE	0.01Ω 12kΩ	0.006Ω 20kΩ	0.006Ω 62kΩ	0.006Ω 130 kΩ	
Qualified Ohmic Range		NF C 83-210	0.1Ω 2.7kΩ	0.1Ω 4.99kΩ	0.1Ω 11.8kΩ	0.1Ω 33.2kΩ	
Minimum Ohmic Values in Relation to Tolerance	E 96	± 0.1%	1Ω		1Ω		
	E 96	± 0.5%	0.1Ω		0.1Ω		
	E 96	± 1%	0.1Ω		0.05Ω		
	E 48	± 2%	0.01Ω		0.01Ω		
	E 24	± 5%	0.01Ω		0.01Ω		
	E 12	± 10%	0.01Ω	0.008Ω	0.006Ω		

€ Undergoes European Quality Insurance System (CECC)



PERFORMANCE			
TESTS	MIL-R-18546 D	NF C 83-210	TYPICAL DRIFTS
	CONDITIONS		
Operating Temperature Range	- 55°C + 200°C		-
Momentary Overload	5Pr/5s		± (0.25% + 0.05Ω)
Climatic Sequence	- 55°C + 200°C 5 cycles		± (0.25% + 0.05Ω)
Load Life Test at High Temperature	2h at + 275°C		± (1% + 0.05Ω) Ins. resistance ≥ 1GΩ
Humidity (Steady State)	56 days		± (1% + 0.05) Ins. resistance ≥ 100MΩ
Resistance to Moisture	Climatic sequences test, with load and polarisation		± (1% + 0.05Ω)
Temperature Coefficient	5 to 10Ω > 10Ω		± 50ppm/°C ± 25ppm/°C
Load Life at Maximum Temperature	1000h 25°C	Pn MIL VISHAY	± (1% + 0.05Ω)
	200°C	30% of Pn SFERNICE	Ins. resistance ≥ 1GΩ

MOMENTARY OVERLOAD

1. Momentary overload (> 2s):

See example in table below. In all cases, it should be understood that:

- the 12Pn overload applies only to ohmic values ≥ 0.1Ω.
- the overload voltage shall not be higher than that used for the dielectric strength test (see Standard Electrical Specifications).

2. Short time overload (< 2s):

For times shorter than 2 seconds, higher overloads can be sustained in some cases. Consult VISHAY SFERNICE.

POWER LOADING	DURATION
2.5 Pn	10 s
5 Pn	5 s
12 Pn	2 s

POWER RATING CHART

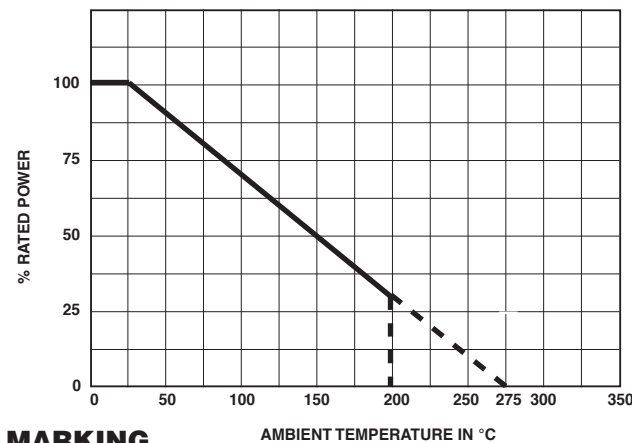

TEMPERATURE RISE

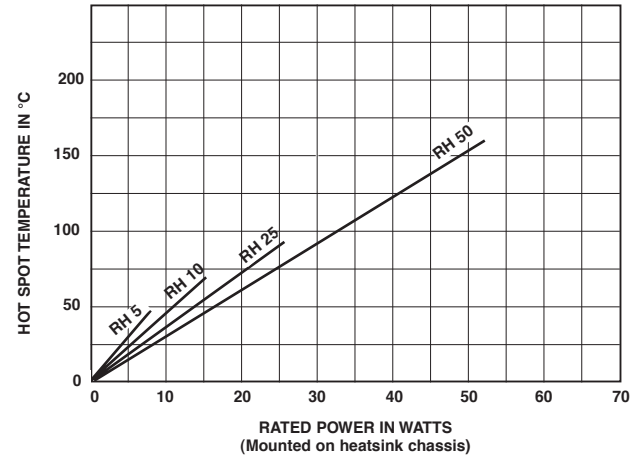

MARKING

VISHAY SFERNICE trademark, model, style, CECC style (if applicable) nominal resistance (in Ω), tolerance (in %), manufacturing date.

ORDERING INFORMATION					
RH	25	NI		150kΩ	± 5%
MODEL	STYLE	NON INDUCTIVE WINDING	SPECIAL DESIGN	OHMIC VALUE	TOLERANCE
		Optional	Method N° Optional	Custom items are subject to extra-charge and min. order. Please see price list.	



Notice

Specifications of the products displayed herein are subject to change without notice. Vishay Intertechnology, Inc., or anyone on its behalf, assumes no responsibility or liability for any errors or inaccuracies.

Information contained herein is intended to provide a product description only. No license, express or implied, by estoppel or otherwise, to any intellectual property rights is granted by this document. Except as provided in Vishay's terms and conditions of sale for such products, Vishay assumes no liability whatsoever, and disclaims any express or implied warranty, relating to sale and/or use of Vishay products including liability or warranties relating to fitness for a particular purpose, merchantability, or infringement of any patent, copyright, or other intellectual property right.

The products shown herein are not designed for use in medical, life-saving, or life-sustaining applications. Customers using or selling these products for use in such applications do so at their own risk and agree to fully indemnify Vishay for any damages resulting from such improper use or sale.